

# Exploded Diagram

Model and code: (PASRW040-P-BP4II-G 10120080)

1 Complete machine structure explosion diagram

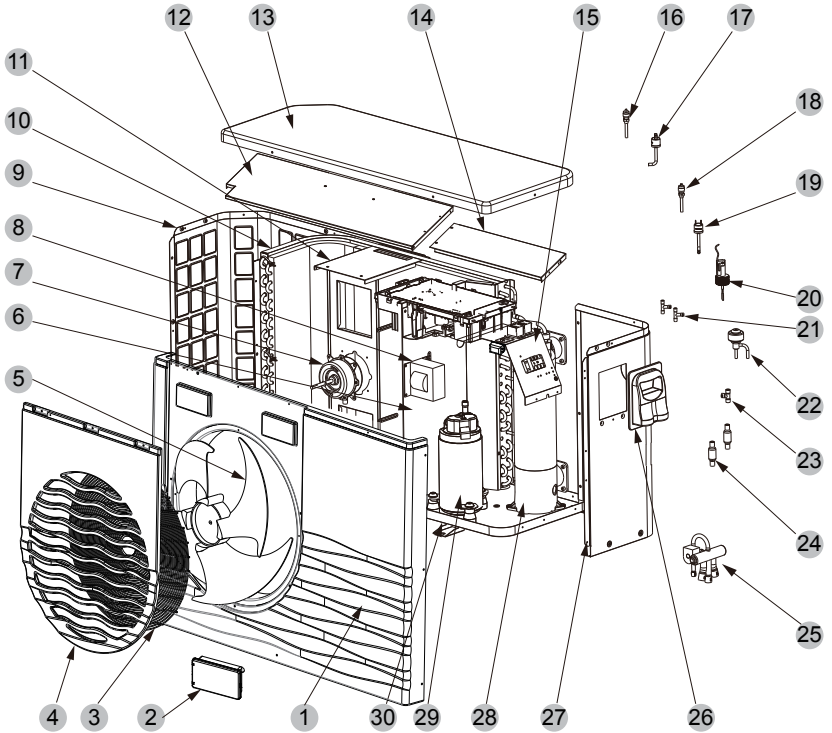

2 Electrical control structure explosion diagram

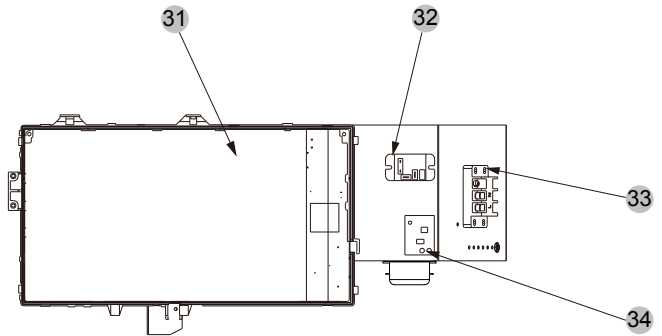

# Exploded Diagram

No.	Code	Name	Specifications	Qty
1	80900274	Front frame	ASA	1
2	95005-310500	CP302 display	20000-430176+35005-310500	1
3	32018-210143	Net	Stainless steel	1
4	80900281	Plastic fan net	ASA	1
5	20000-270004	Axial flow fan blades	Z500-145	1
6	80700324	Middle Plate	Galvanized plate	1
7	20000-330132	Dc motor	ZWS75-A	1
8	82500005	Reactor	R2050FNKZ 20A 50Hz 5.2mH	1
9	80700323	After the network	Galvanized sheet	1
10	80600079	Finned heat exchanger	714×353×800×Φ7×2.2.0	1
11	80700329	Motor bracket	Galvanized plate	1
12	80700327	Top support plate	Galvanized plate	1
13	80900257	Top cover	ASA	1
14	80700701	Top support plate 2	Galvanized plate	1
15	80701513	Electrical box support plate	Galvanized plate	1
16	20000-140150	Needle valve	40mm 1/2"	2
17	20000-360157	Pressure switch	0.30MPa/0.15MPa ±0.05 NO	1
18	20000-140512	Needle valve	95mm 7/16"	1
19	2001-3605	Pressure switch	3.2MPa/4.4MPa ±0.15 NC	1
20	83000068	Water flow switch	PSL-1 3/4	1
21	2000-1460	Tee	Φ6.5-2×Φ6.5(T)×0.75 T2M	2
22	81000017	Electronic expansion valve	DPF(TS1)2.0C-03 (TS120C03)	1
23	304030-00000002	Tee	Φ9.52-2×Φ6.35(T)×1.0	1
24	2004-1444	Filter	Φ9.7-Φ9.7 (Φ28) T2Y2	2
25	2004-1437	Four-way valve	SHF-9H-35U-P/C03C01S	1
26	32009-220029	Junction box body	ABS	1
27	80700581	Right side plate	Galvanized plate	1
28	72300007	Titanium tube heat exchanger	Φ12.7×12m Φ160	1
29	80100046	Compressor	SVB220FLGMC-L	1
30	80700321	Chassis	Galvanized plate	1
31	72200167	Frequency conversion board	82300129+82400156	1
32	20000-360297	Relay	HATF903AS30AC220 AC220V 30A	1
33	4000-3901	5 bit wiring block	RS9101C-5(450V~ 4mm2 )(L、N、PE、1、2)	1