

Exploded Diagram

Model and code:(10120082 PASRW040S-P-BP4-G)

1 Complete machine structure explosion diagram

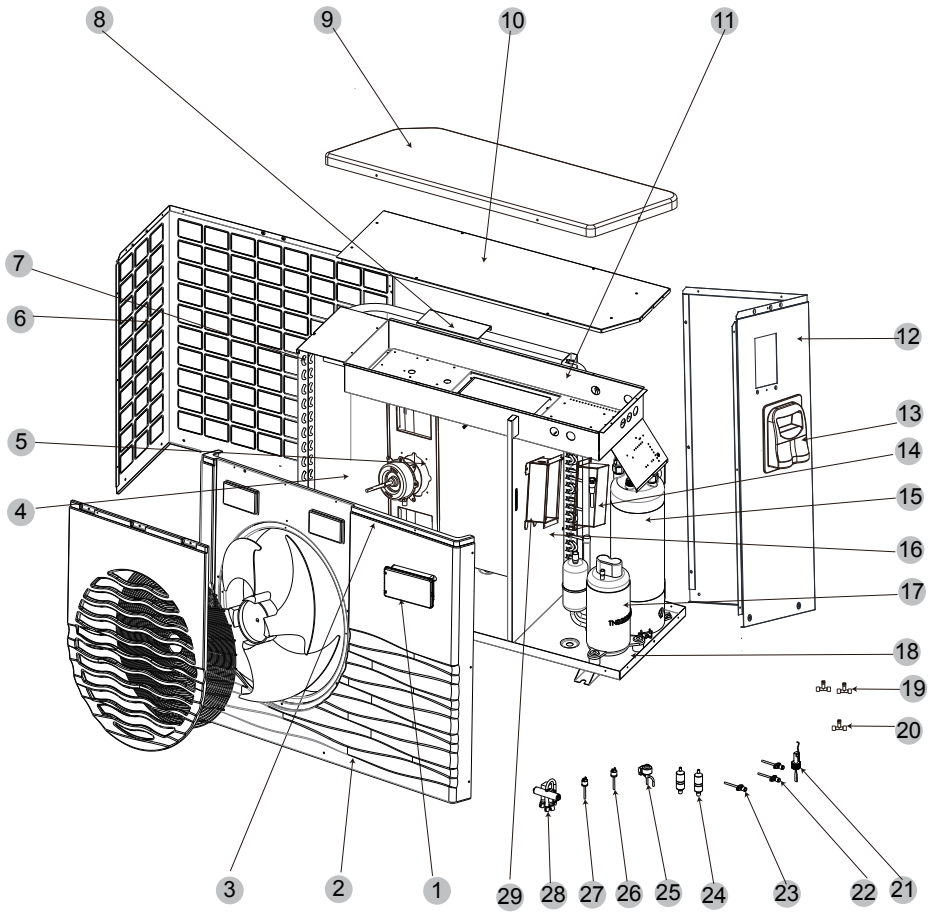

2 Electrical control structure explosion diagram

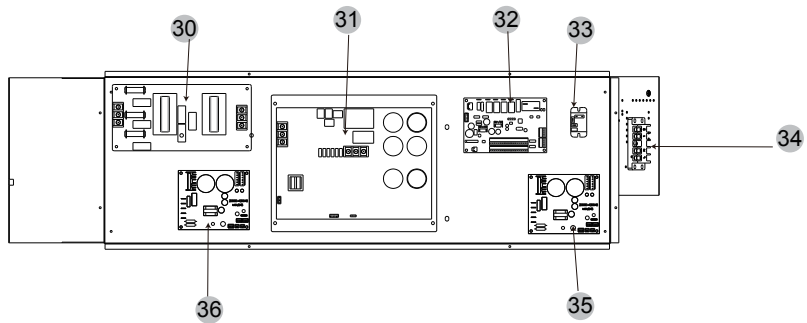

Exploded Diagram

No.	Code	Name	Specifications	Qty
1	95005-310500	LCP302 display	20000-430176+35005-310500	1
2	80900274	Front panel	ASA	1
3	80900281	Baffle	ASA	1
4	20000-270004	Axial fan blade	Z500-145	1
5	20000-330132	DC	ZWS75-A	1
6	80702268	Back net	Galvanized sheet	1
7	80600079	Fin heat exchanger	714 × 353 × 800 × Φ7 × 2	1
8	80700330	Motor bracket assembly	ASA	1
9	80900300	Top cover	Galvanized sheet	1
10	301070-20090002-02	Electrical box support plate	Galvanized sheet	1
11	301070-20090009	Electrical box components	Galvanized sheet	1
12	80700581	Right plate	Galvanized sheet	1
13	32009-220029	Junction box body	ABS	1
14	80701839	Explosion-proof box top cover	Galvanized sheet	1
15	72300007	Titanium tube heat exchanger	Φ12.7 × 12m Φ160	1
16	80700325	Middle partition	Galvanized sheet	1
17	80100065	compressor	SVB220FSAMC-L	1
18	80702266	Chassis	Galvanized sheet	1
19	2000-1460	Tee	Φ6.5-2 × Φ6.5 (T) × 0.75 T2M	2
20	304030-00000002	Tee	Φ9.52-2 × Φ6.35 (T) × 1.0	1
21	83000069	Flow switch	PSL-1 3/4	1
22	20000-140150	Needle valve	40mm 1/2	2
23	20000-140512	Needle valve	95mm 7/16	1
24	2004-1444	filter	Φ9.7-Φ9.7 T2Y2	2
25	20000-140450	Electronic expansion valve	DPF 2.0C-03	1
26	2001-3605	Pressure Switch	3.2MPa / 4.4MPa ± 0.15	1
27	20000-360157	Pressure Switch	0.30MPa / 0.15MPa ± 0.05	1
28	2004-1437	Four-way valve and its accessories	SHF-9H-35U-P / C03C01S	1
29	80702226	Explosion-proof box base assembly	Galvanized sheet	1
30	82300074	Filter board	1AC32I20WL2	1
31	82300084	Driver module	2AC32I23WM1	1
32	72200052	Fan speed regulating module	20000-430228 + 35005-310617	1
33	20000-360297	Relay	HATF903AS30AC220	1

