

Exploded Diagram

Model and code:(Cube 2.5)

1 Complete machine structure explosion diagram

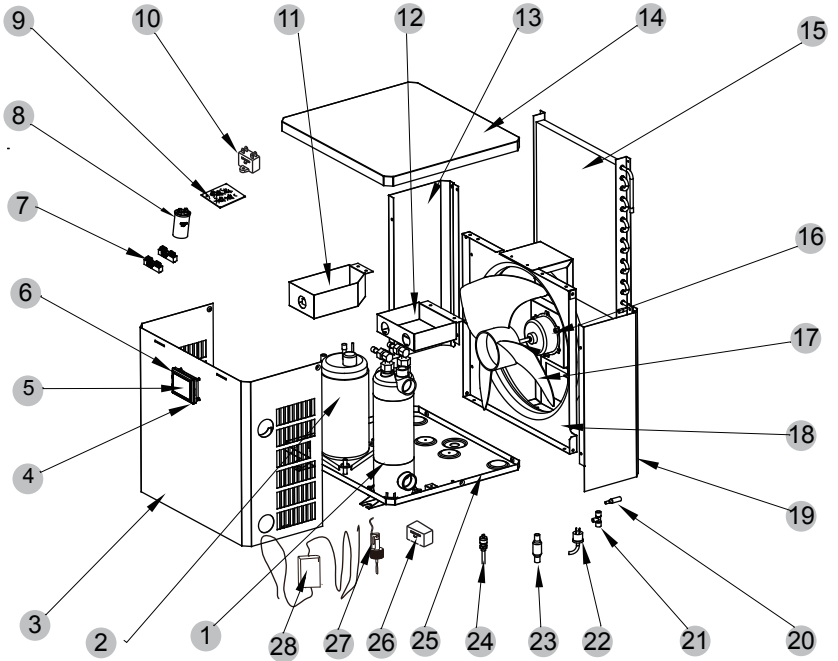

Exploded Diagram

No.	Code	Name	Specifications	Qty
1	80600495	Titanium heat exchanger	Φ9.52×2m Φ90	1
2	80100111	Compressor	QXF-A071L190	1
3	80704860	Front panel	Grey matte7043	1
4	80900578	Waterproof box base	PC黑色 80×62×33.6	1
5	82300143	LED208	MXL271	1
6	80900577	Waterproof box top cover	PC Black 82.8×60×9.8	1
7	2000-3909	Terminal Board(2 bit)	RS9211(450V~4mm2)	2
8	2000-3514	Compressor capacitance	CBB65-25μF/450V P2	1
9	82300156	MN1001	MXL273	1
10	2000-3506	Fan capacitance	CBB61-2μF/500V(印450V)P2	1
11	80704865	Electrical box 1	Black 9005	1
12	80704866	Electrical box 2	Black 9005	1
13	80705105	Left side plate	Grey matte7043	1
14	80704861	Roof assembly	Grey matte7043	1
15	80600476	Fin heat exchanger	310×375×Φ7×1	1
16	80200131	Fan motor	SA25C14	1
17	80300016	Fan blade	Φ320×119-Φ8(7)×3	1
18	80704859	Fan motor support	Black 9005	1
19	80705106	Right side plate	Grey matte7043	1
20	20000-140066	Variable diameter	Φ9.52(外)-Φ2.9(内)×0.75 T2M	1
21	304030-00000002	Tee	Φ9.52-2×Φ6.35(T)×1.0	2
22	20000-360059	High pressure switch	3.2MPa/4.0MPa ±0.15 常闭	1
23	2003-1411	Filter	Φ9.7-Φ2.9(Φ20) T2Y2	1
24	20000-140150	Needle	40mm 1/2"	1
25	80704862	Chassis	Grey matte7043	1
26	20000-360297	Relay	HATF903AS30AC220 AC220V 30A	1
27	83000068	Water flow switch	PSL-1 3/4内牙全塑 2300GS	1
28	82700145	The power plug	3x1mm ² H05RRR-F 250VAC 16A 4m	1